

Chevi Group

**DECADES OF DEDICATION
TO THE NATION**

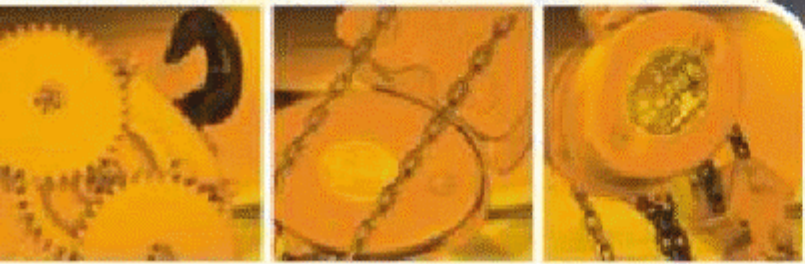

MORRIS - 'RS' CHAIN PULLEY BLOCK



'MORRIS' RS Series Balanced Spur Gear Hand Chain Hoists are offered in ten capacities in the range from **0.5 Tonne to 20 Tonne.**

Hook suspension is available for all capacities and all hook suspension hoists can be hung into Morris push or hand geared Traveling Trolleys.

Built-in or dose-lift units built into hand geared trolleys are offered from **0.5 to 20 Tonne capacities.**

FRAME :

Made from MS Rolled Steel Plates.
A detachable cover totally encloses the gears.

CHAINS :

Load chains are of Alloy Steel Grade 80 to IS: 6216.
For 0.5 Tonne is of Higher Tensile Steel Grade 40 to IS: 3109 (Part II).

HOOKS :

Forged hook as per IS: 8610

GEARS:

Heat-treated alloy steel pinions and case hardened spur wheels.

LOAD WHEEL :

Made from Spheroidal Graphite Iron.

BEARINGS :

Load spur wheel mounted on Ball Bearings.

BRAKE :

The brake is of automatic screw and discs type.

CHAIN GUIDES :

Steel chain guide roller provided

HAND CHAIN WHEEL :

Made from Cast Iron FG 200/220 to IS: 210.

SPARES :

Easy inter-changeable spare available ex-stock.

LUBRICATION :

Totally enclosed gear case is packed with sufficient grease.

EACH CHAIN PULLEY BLOCK IS SUBJECTED TO 50% OVERLOAD.

● Also available higher capacity Chain Pully Block(25 Tonne to 40 Tonne)

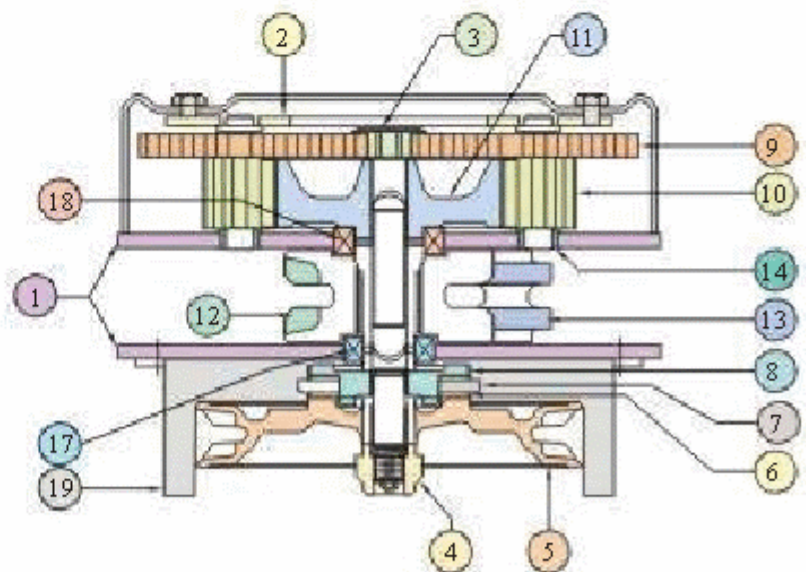
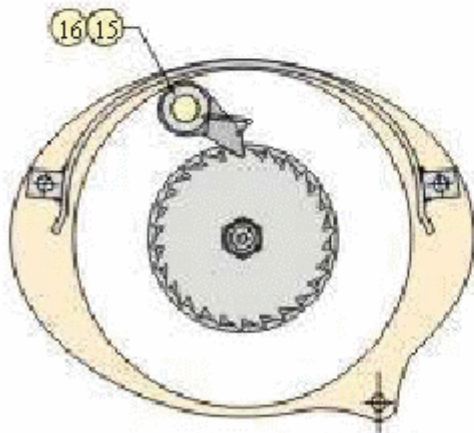

One year guarantee from the date of installation
(or) 18 months from the date of supply, whichever is earlier.

- ① HOUSING ② TOP PLATE ③ DRIVING PINION ④ CASTLE NUT WITH WASHER ⑤ HAND CHAIN WHEEL
- ⑥ FRICTION WASHER ⑦ RATCHET WHEEL ⑧ DISC HUB ⑨ INTER SPUR WHEEL ⑩ INTERMEDIATE PINION
- ⑪ LOAD SPUR WHEEL ⑫ LOAD CHAIN WHEEL ⑬ GUIDE ROLLER WITH ROLLER PIN ⑭ CS BUSH
- ⑮ RATCHET PAWL (WITH BUSH) ⑯ PAWL SPRING ⑰ BEARING ⑱ BEARING ⑲ HAND CHAIN GUARD

'MORRIS' RS Chain Pulley Block - Dimensions, weights and performance data"

Capacity (Safe Working load)	Tonnes	0.5	1.0	2.0	3.0	5.0	10.0	15.0	20.0
Number of Falls of load chain		1	1	2	1	2	3	6	8
Load chain Dia	mm	6.5	6.3	6.3	10.0	10.0	12.0	12.0	12.0
Load chain Grade	---	40	80	80	80	80	80	80	80
Test Load	Tonnes	0.75	1.50	3.00	4.50	7.50	15.00	22.50	30.00

Dimensions

A Hook suspension	mm	360	360	540	560	720	1000	1430	1675
Hung in Trolley	mm	465	465	670	695	875	1235	1830	2200
Built-in Type (Close-lift)	mm	415	415	510	575	700	1000	1165	---
B	mm	210	210	240	330	380	610	1175	1370
C	mm	162	162	162	213	213	254	292	330

Hung in Trolley

Track width Range-I	mm	75-125	75-125	80-140	80-150	100-150	140-210	140-210	140-210
Track width Range-II	mm	140-180	140-180	150-210	180-210	180-210	---	---	---
Minimum clear depth of track	mm	125	125	150	150	200	300	300	450

Built-in Units

Track width Range-I	mm	75-125	75-125	80-140	80-150	100-150	140-210	140-210	---
Track width Range-II	mm	140-180	140-180	150-210	180-210	180-210	---	---	---
Minimum clear depth of track	mm	125	125	150	150	200	300	300	---
Minimum radius of track curve	m	1.5	1.5	2.0	2.0	2.5	3.5	3.8	4.0

Weight

Hook suspension unit for 3M clear lift	kg	16.5	16.5	22	43	68	160	820	940
Additional weight for extra mtr lift	kg	1.8	1.8	2.5	3.5	5.5	12	24	30
Geared Trolley with chain for standard 3M clear lift	kg	23	23	37	42	85	240	467	552

Effort

On hand chain to raise SWL	kg	15	27	32	45	42	80	2 x 70	2 x 80
----------------------------	----	----	----	----	----	----	----	--------	--------

Velocity Ratio

Movement of hand chain to load chain		52	52	104	94	188	186	372	500
--------------------------------------	--	----	----	-----	----	-----	-----	-----	-----

Our Engineering Department continuously works on design improvements and hence, we reserve the right of effecting any change without notice.

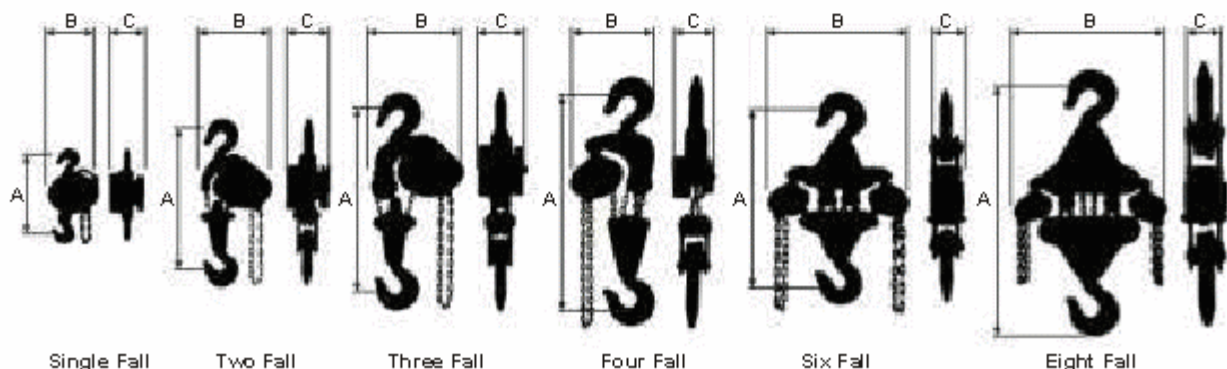

'MORRIS' Travelling Trolleys have low headroom and are designed & manufactured for efficient transportation of loads

FRAME : Made from MS Rolled Steel Plates.

TROLLEY ADJUSTMENT : Side plates can be easily adjusted for different beam sizes by re-locating the spacers.

WHEELS : Made from Cast Iron FG 200/220 to IS: 210. Deep & wide flanges prevent the wheels from climbing the track. Each wheel is mounted on two anti friction ball bearings for smooth, easy rolling and better stability.

OTHER FEATURES : Trolleys can negotiate small radius of curvature & this feature makes it possible to install trolley for efficient transportation of loads in areas of limited space.

One year guarantee from the date of installation (or) 18 months from the date of supply, whichever is earlier.

1 year
guarantee

Capacity (Safe Working load)	Tonnes	1.0	2.0	3.0	5.0	7.5	10.0
Test load	Tonnes	1.50	3.00	4.50	7.50	11.25	15.00
Track Width	Range-I	mm	75-125	80-140	80-150	100-150	140-210
	Range-II	mm	140-180	150-210	180-210	180-210	--
Minimum clear depth of track	mm	125	150	150	200	300	300
Minimum radius of track curve	mm	1.5	2.0	2.0	2.5	3.5	3.5
Major Dimensions	C	mm	104	130	135	155	233
	D	mm	124	160	165	190	335
	E	mm	63	100	100	120	180
	F	mm	27	29	29	40	49
	L Range-I	mm	107	120	137	166	190
	L Range-II	mm	134	155	167	196	--
Geared Trolley	A	mm	125	181	181	207	280
	B	mm	136	201	201	234	308
	H	mm	114	133	133	161	363
	J	mm	89	130	130	150	216
	K	mm	140	160	160	197	235
Ungeared Trolley	A	mm	118	164	164	192	530
	B	mm	136	201	201	234	308
Weight (approx) for 3m clear lift	kg	23	37	42	81	214	220
Effort on hand chain to raise SWL	kg	9	14	16	26	34	36
Displacement achieved by 30M of hand chain	m	4.4	7.8	6.2	6.8	6.7	6.0

Our Engineering Department continuously works on design improvements and hence, we reserve the right of effecting any change without notice.

GEARED TRAVELLING TROLLEY

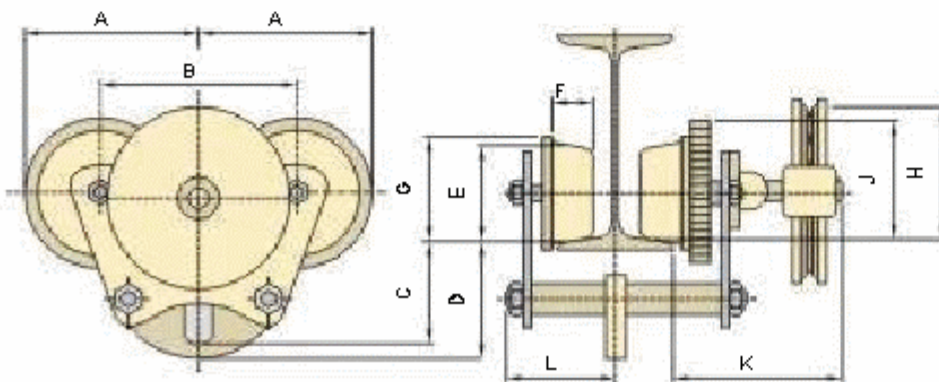

chevigroup.com

The name that
carries weight
in more ways than one